

RESISTOFLEX

SINCE 1947

Vibration Shock Seismic Control

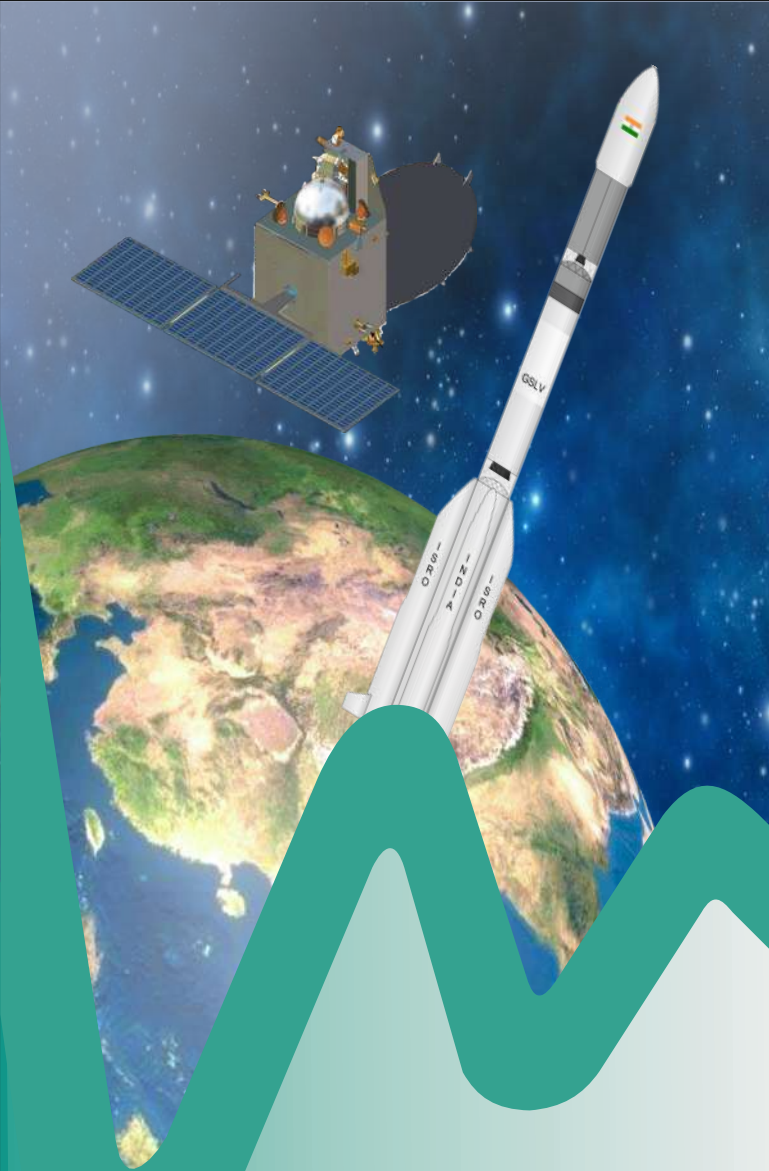

- SHOCK & VIBRATION MOUNTINGS
- EXPANSION JOINTS
- BASE ISOLATION SYSTEMS

for

DEFENCE & SPACE

AIR SPRINGS & SUSPENSION SYSTEMS

VIBRATION - SHOCK SEISMIC ISOLATION



Comprehensive range with load capacity from a few grams to several hundred tonnes.

- Rubber Metal Bonded Mountings, Pads, Mats, Carpets.
- Helical Spring Isolators, Restrained Spring Isolators, Enclosed Spring Isolators, Viscous Dampers.
- Seismic Snubbers & Mountings
- Inertia Pouring Frames, Floating Concrete Bases, Pump Bases.
- Rubber Hangers, Spring Hangers, Pipe Guides, Pipe Supports, Combined Rubber Spring Hangers, Thrust Restraints.
- Rubber Expansion Joints, Bellows, Duct Connectors, Wall Sleeves, etc.

ABOUT US

RESISTOFLEX was founded in 1947 by Late Mr. R.K. Jain after graduating in Electrical & Mechanical Engineering from BHU, India. He was joined by Mr. Ratish Jain, B.Tech & Silver medallist from IIT Delhi. He forged several alliances with globally acclaimed companies in related fields. Further RESISTOFLEX was co-opted to the Mechanical Vibration and Shock Sectional Committee of Bureau of Indian Standards.

RESISTOFLEX offers a most comprehensive range of products comprising of :

- Application Engineering
 - Shock, Vibration & Seismic Engineering
 - Flexible Piping Systems
- for
- Industrial Equipments
 - Machine Tools & Forging Hammers
 - Heavy Machines
 - Army Vehicles, Tanks, Shelters
 - Naval Ships & Submarines
 - Aerospace
- Air Spring Systems
 - Automatic Door Systems
- for
- Railways
- Base Isolation Systems
- for
- Building & Bridges

RESISTOFLEX offers complete engineering services which includes : Diagnostic Investigation, Technical Analysis, System Design, Supervision of Installation, Performance Evaluation & Post Monitoring.

RESISTOFLEX has advanced computer programs and decades of experience to design and recommend the most efficient and economical isolation system for applications as diversified as passive insulation of Delicate Instruments and active isolation of massive Forging Hammers.

Nearly one million products are made on floor area of over 150000 sq. ft. in 4 modern plants equipped with latest manufacturing and dynamic test facilities.

Many products are regularly exported to U.S.A., U.K., France, Germany, Middle East, Taiwan, Korea, etc

CORPORATE OFFICE AND PLANTS

CORPORATE HEADQUARTERS
AT NOIDA



NOIDA OFFICE AND PLANT

NOIDA PLANT II



GREATER NOIDA PLANT



DEFENCE & SPACE

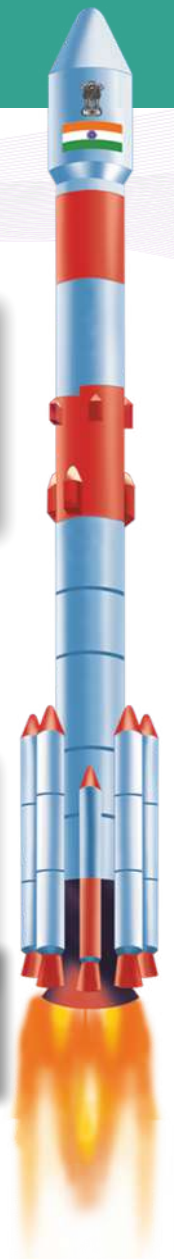

ACOUSTIC TILES FOR SIGNATURE MANAGEMENT

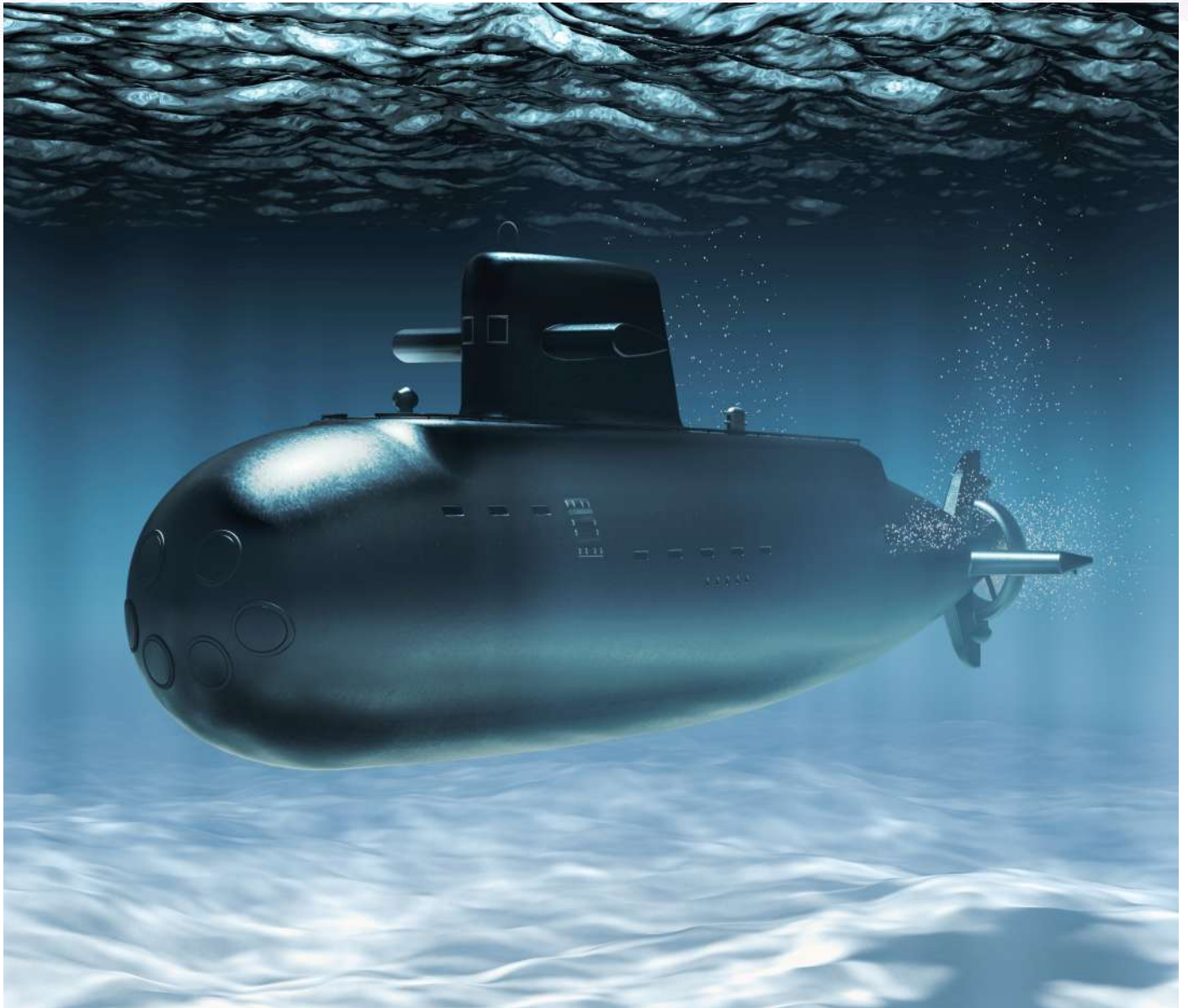

Every Submarine has an unique & distinctive signature. Our Acoustic Rubber Tiles encapsulate the entire submarine to modify or manipulate these signatures to confuse the enemy. This technique of SIGNATURE MANAGEMENT enhances safety.

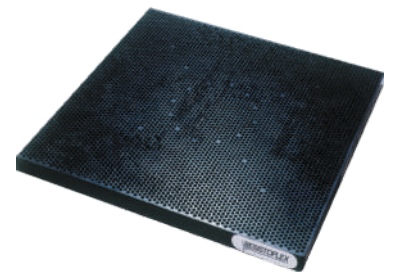

....VITAL FOR SURVIVAL

SHOCK & VIBRATION MOUNTINGS FOR NAVAL SHIPS



Shock & Vibration Mountings, Air Mounts, Cable Mounts, Bellows, Dampers.....

Quality, Reliability, Precision and Innovation are our fundamentals for the vital role, these products have to play in the complex modern Defence Systems. Performance is assured under extreme environmental conditions. Mounts are TYPE APPROVED & withstood BARGE TEST, the most severe NAVAL SHOCK qualifying test.

Validated Software Proware Programs Analyze Systems including NAVAL SHOCK NSS I & II to select mounts. Our Mounts protect delicate electronic equipments in European Naval Vessels.

Engineered to Perform.....

ISOLATION OF EQUIPMENTS ON BOARD NAVAL SHIPS

Centrifugal Separator



Air-conditioner



Electrical Panels



Sensitive Equipment Case

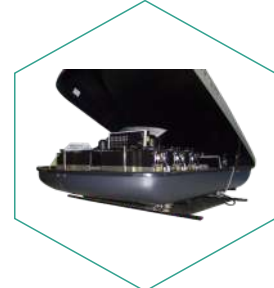

Console

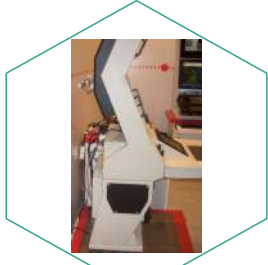

Fuel Oil Centrifuge



Turbo Blower



Pneumatic Compressor



Main Engine

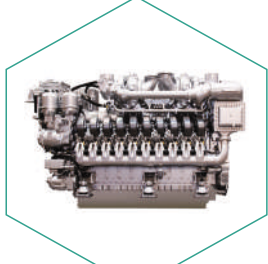

Steering Gear

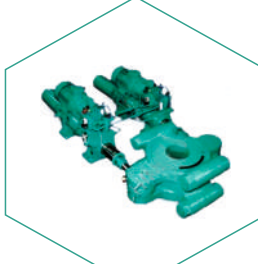

Refrigeration Compressor

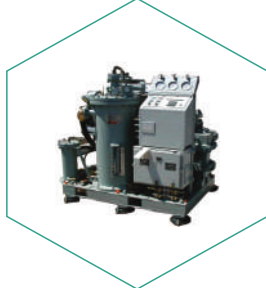

Synthetic Aperture Radar



Bulk Head Panel



Bilge Pump



Chiller

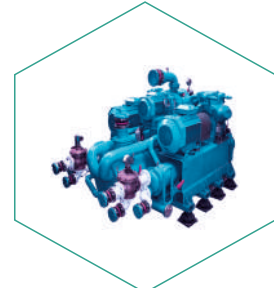

Diesel Alternator

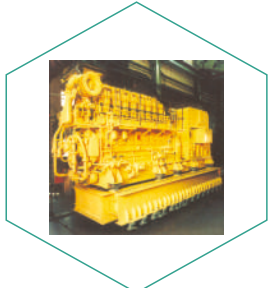

Gas Turbine



Rocket Panels



Sensitive Electronic System



Refrigeration Plant



SPACE

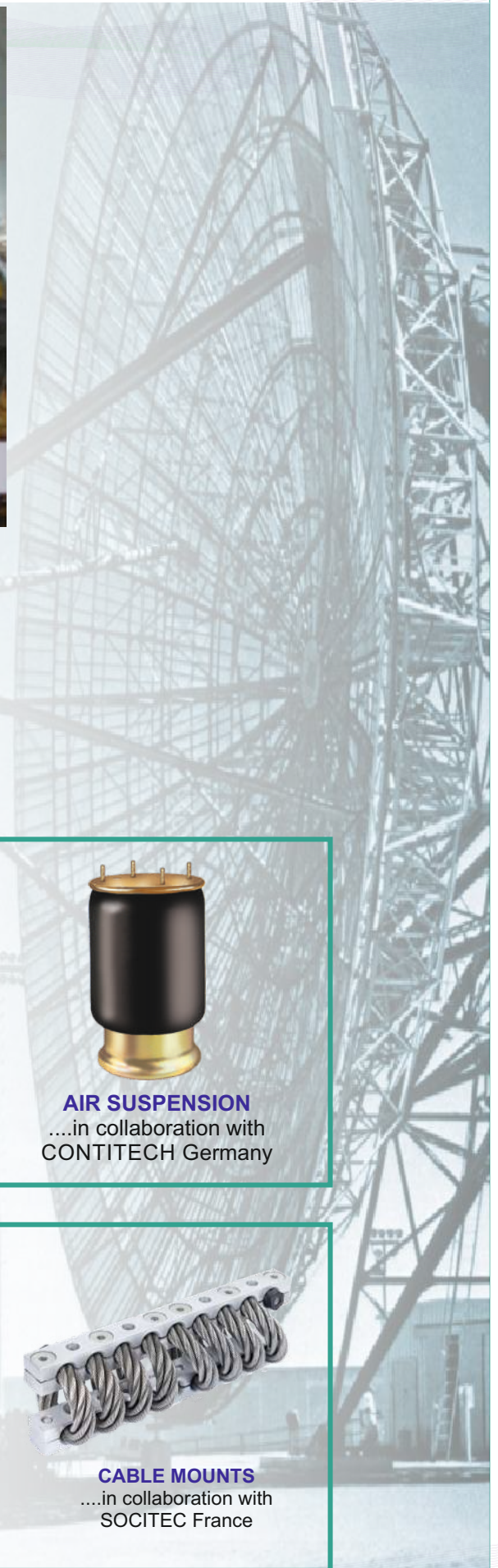

X LEAF SPRING MOUNTS
...in collaboration with
CHRISTIE & GREY UK



**SILICON ISOLATORS
IN FLIGHT**
...in collaboration with
VSSC India



AIR SUSPENSION
...in collaboration with
CONTITECH Germany



CABLE MOUNTS
...in collaboration with
SOCITEC France

PROTECTION DURING TRANSPORTATION

Air Suspension Systems, Cable & Elastomeric Mounts turn bumpy roads into smooth highways

Protecting Instruments, Radars, Computers, Disc Drives, CRT, AC Units, Electrical Cabinets, Switch Boxes, Telecommunication Equipments, Electronic Racks, Generators etc. installed in Ground Support Vehicles, Shelters & Battle Tanks, Missiles, Torpedoes, Engines, Space Satellites during transportation.



DESIGN

In-House capabilities for Designing & Manufacturing including analysis such as static and dynamic characteristics with testing validation... to ensure highest levels of production and quality for assured performance.

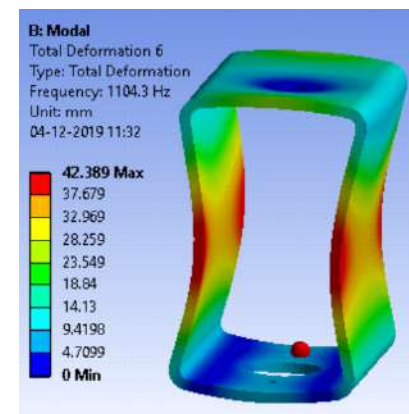
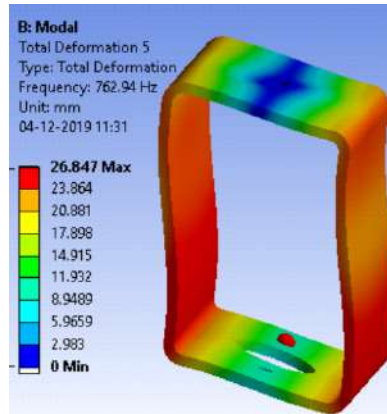
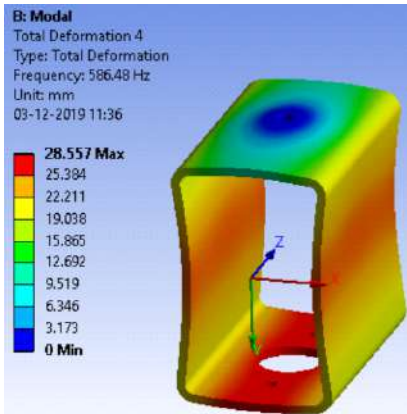
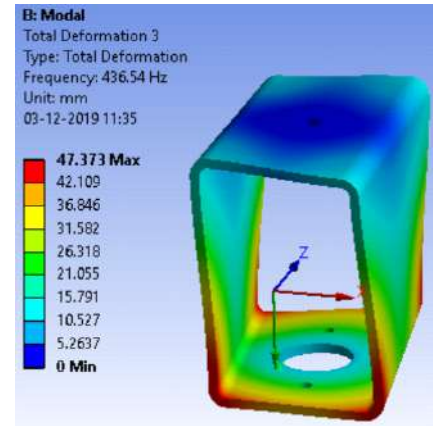
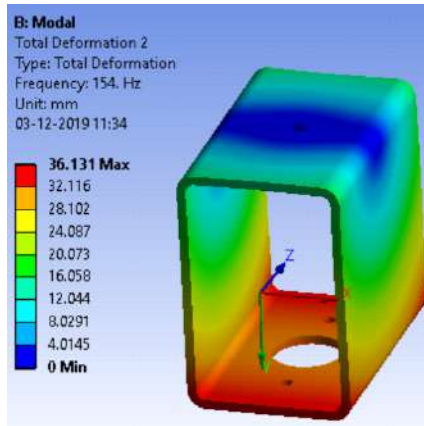
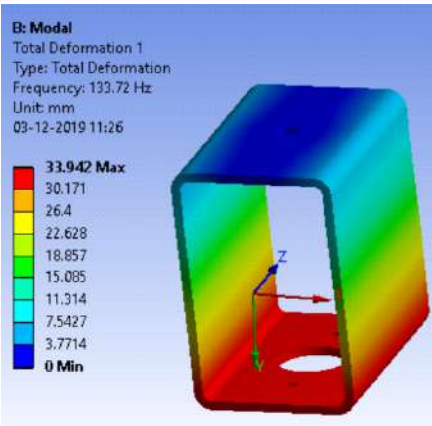

Phase Response

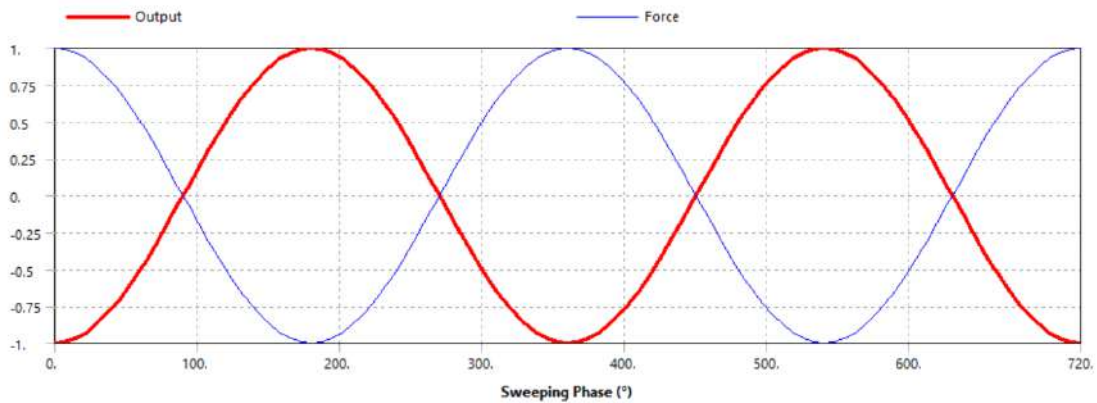

	(g)	(ms)
1/2 Sinus 1Z	50	11
1/2 Sinus 2Z	0	0

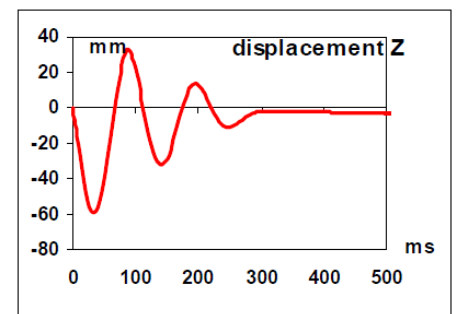
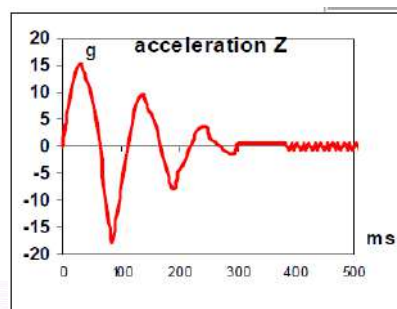

TESTING - RESEARCH

Manufacturing



Testing

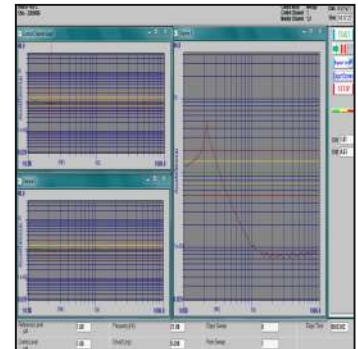
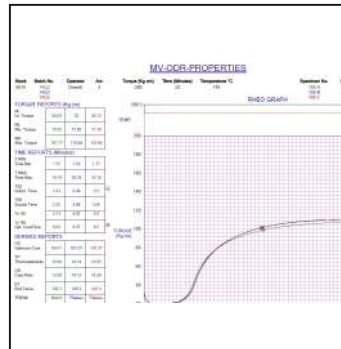
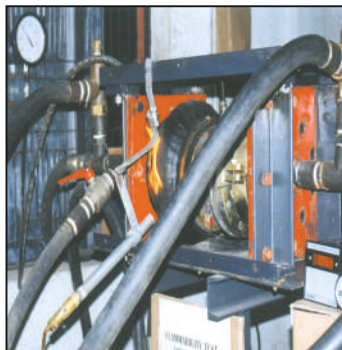

Naval Science & Technological Laboratory

Fax : 4891 - 255444
Phone : 258479
E-mail : shank.m@resistoflex.in

Ref: NSTL/RES/2008/2100/15

To, Mrs Resistoflex (P) Ltd B 102, Sector V, Noida 201 301

Attn: Mr Harish Chandra,

Dear Sir,

Refer your letter HC/NSTL/Type Test/04 Laboratory for Testing of your Shock & Vibe

We place at Annexure:-
Appendix A (04 Pages) for Shock & Vibe as per Drawing of Type M attached
Appendix B (05 Pages) for Shock & Vibe -L10 to L112) as per Drawing of Type L, attached
We confirm that the Mounts, under Test, are of Type Test and Shock Test of NSS Grade

Thanking you,

(Signature)

Fax : 4891 - 255444
Phone : 258479
E-mail : shank.m@resistoflex.in

Ref: NSTL/RES/2008/1700/15

To, Mrs Resistoflex (P) Ltd B 102, Sector V, Noida 201 301

Attn: Mr Harish Chandra,

Dear Sir,

Refer your letter HC/NSTL/Type Test/01 this Laboratory for Testing of your Shock & Vibe

We place at Annexure:-
Appendix A (04 Pages) for Shock Mounting Drawing T.U.(I)3776KME081 attached.
Appendix B (04 Pages) for Vertical Mean NSTL-01 (02 Sizes) as per Drawing of NY Attached
Appendix C (04 Pages) for Triangular Isokin Drawing of HD Attached

We confirm that the Mounts, under Test, are of Type Test and Shock Test of NSS Grade 1

Thanking you,

(Signature)

Fax : 4891 - 255444
Phone : 258479
E-mail : shank.m@resistoflex.in

Ref: NSTL/RES/2008/3200/15

To, Mrs Resistoflex (P) Ltd B 102, Sector V, Noida 201 301

Attn: Mr Harish Chandra, V. Prasad

Dear Sir,

Refer your letter HC/NSTL/Type Test/05-01-01 this Laboratory for Testing of your Shock & Vibration

We place at Annexure:-
Appendix 1 (04 Pages) for Angular Shock Mount (Size) as per Drawing AD/P1 1450 & 454 attached.
Appendix 1 (04 Pages) for Conical Isokin Type II Drawing of IC 540 Attached
Appendix 1 (04 Pages) for Conical Spring & Its TSC -1 (01 Size) as per Drawing Type TSC-1

We confirm that the Mounts, under Test, are of Type Test and Shock Test of NSS Grade 1

Thanking you,

(Signature)

Fax : 4891 - 255444
Phone : 258479
E-mail : shank.m@resistoflex.in

Ref: NSTL/RES/2008/1400/15

To, Mrs Resistoflex (P) Ltd B 102, Sector V, Noida 201 301

Attn: Mr Harish Chandra, V. Prasad-Mr

Dear Sir,

Refer your letter HC/NSTL/Type Test/06-01-01 this Laboratory for Testing of your Shock & Vibration Mounts

We place at Annexure:-
Appendix 1 (04 Pages) for Vibration Shock Mounting Typ PSD, P7D, P3 1.00 as per Drawing Type PD attached.
Appendix 1 (05 Pages) for Grooves Rubber Mounting Type GF-05, B55, B40, B70 & GF-HD-05, HD-05, HD-05, HD-09, II as per Drawing of Grooves GF Attached

We confirm that the Mounts, under Test, are of Type Test and Shock Test of NSS Grade 1

Thanking you,

(Signature)

Fax : 4891 - 255444
Phone : 258479
E-mail : shank.m@resistoflex.in

Ref: NSTL/RES/2008/2400/15

To, Mrs Resistoflex (P) Ltd B 102, Sector V, Noida 201 301

Attn: Mr Harish Chandra, V. Prasad- Marketing

Dear Sir,

Refer your letter HC/NSTL/Type Test/05-01-08 April 2015 requesting this Laboratory for Testing of your Shock & Vibration Mounts

We place at Annexure:-
Appendix A (04 Pages) for Shock & Vibration Mounting Type X (05 Size -X-10 to X-40) as per Drawing of Type 'X' attached
Appendix B (06 Pages) for Shock & Vibration Mounting Type Y (08 Size -Y-10 to Y-40) as per Drawing of Type Y attached

We confirm that the Mounts, under Test, are of Type Test and Shock Test of NSS Grade 1

Thanking you,

(Signature)

Fax : 4891 - 255444
Phone : 258479
E-mail : shank.m@resistoflex.in

Ref: NSTL/RES/2008/2400/15

To, Mrs Resistoflex (P) Ltd B 102, Sector V, Noida 201 301

Attn: Mr Harish Chandra, V. Prasad- Marketing

Dear Sir,

Refer your letter HC/NSTL/Type Test/05-01-08 April 2015 requesting this Laboratory for Testing of your Shock & Vibration Mounts

We place at Annexure:-
Appendix A (04 Pages) for Shock & Vibration Mounting Type X (05 Size -X-10 to X-40) as per Drawing of Type 'X' attached
Appendix B (06 Pages) for Shock & Vibration Mounting Type Y (08 Size -Y-10 to Y-40) as per Drawing of Type Y attached

We confirm that the Mounts, under Test, are of Type Test and Shock Test of NSS Grade 1

Thanking you,

(Signature)

Yours faithfully,
A.N.S. Choudhary
Sr. Chief
Sr. Chief
Sr. Chief
Sr. Chief
Sr. Chief
Sr. Chief

CHANDRAYAAN 2

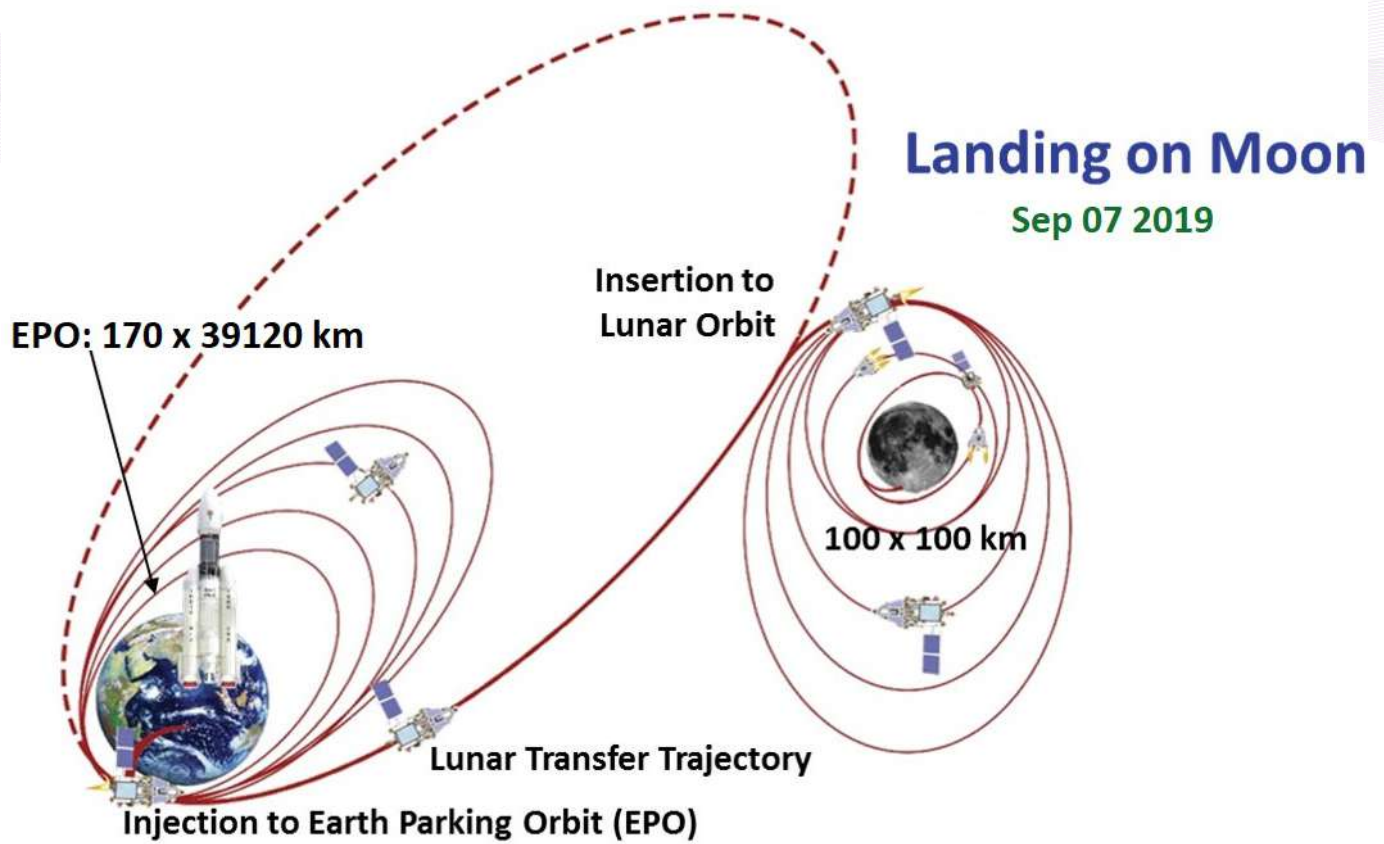

P16 LHB Air Spring for Indian Railways used in Air Bearings for Dynamic Characterization of launch vehicle to assist Auto Pilot in controlling final Lunar Transfer Trajectory.

Our

- Innovative Capabilities
- Synchronized Technologies



INDIAN LUNAR MISSION 2019



Chandrayaan 2 is an Indian lunar mission that will boldly go where no country has ever gone before — the Moon's south polar region. It will attempt to soft land the lander -Vikram and rover- Pragyan in a high plain between two craters.

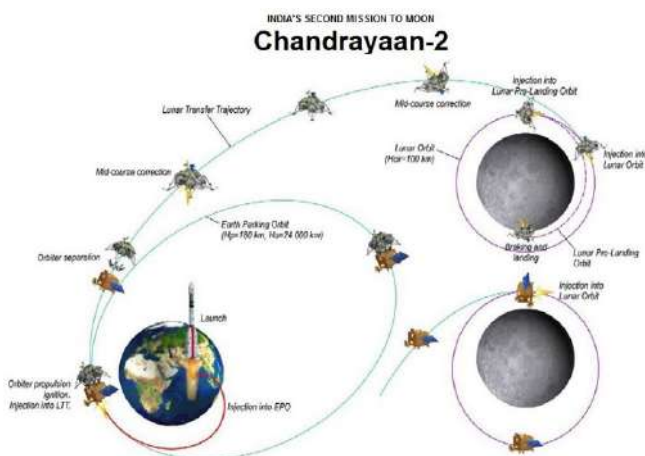

Approx. 200 Nos Silicone Vibration Isolators insulate Avionic Modules from harsh vibration, noise and nano shocks during lift off and stage separations of GSLV - Mk III-M1 to the final deployment of Satellite in the moon's orbit.

CERTIFICATIONS



CERTIFICATE

awarded to
RESISTOFLEX DYNAMICS PRIVATE LIMITED
 PLOT NO:- 27-28, UDYOG VIHAR, GREATER NOIDA
 201306, GAUTAM BUDDH NAGAR, UTTAR PRADESH
 India

DQS GmbH

confirms, as an IRIS Certification[®] approved certification body, that the
 Management System of the above organization has been assessed and found to
 be in accordance with the

IRIS Certification[®] Conformity assessment:2020
and based on
ISO/TS 22163:2017

for the activities of Design and Development and Manufacturing
 for the scope of certification: 03 (Guidance)
 of Air Spring Assembly

Certificate valid from: 29/11/2021

Certificate valid until: 13/10/2024*



Current date: 02/12/2021
 Certificate-Register-No: 50254232

* Providing that the subsequent surveillance audits are successful before the validity date of the previous audit.
 Certification body address: August-Schanz-Straße 21, 60433 Frankfurt am Main, Germany

©2021 UNIFE. All rights reserved.
1/2



Certificate of Registration

This certificate has been awarded to

Resistoflex Dynamics Pvt. Ltd.

Plot No.- 27-28, Udyog Vihar, Greater Noida, Uttar Pradesh, 201306, India

In recognition of the organization's Quality Management System which complies with

ISO 9001:2015

The scope of activities covered by this certificate is defined below

Design, Manufacture and Marketing of Air Spring Assembly, Air Suspension System, Fabricated Metal Parts, Rubber and Metal Expansion Joints

Certificate Number: 57267/A/0001/IN/In			
Date of Issue of Certification Cycle	Issue Number	Certificate Expiry Date	Certification Cycle
11 February 2022	5	10 February 2025	4
Revision Date	Revision Number	Original Certificate Issue Date	Scheme Number
29 January 2022	0	11 February 2021	n/a

For detailed explanation for the data fields above, refer to <http://www.urs-holdings.com/logos-and-regulations>

Issued by



On behalf of the Schemes Manager







Certificate of Registration

This certificate has been awarded to

Resistoflex Pvt. Ltd.

B-103, Sector-5, Noida, Uttar Pradesh, 201301, India

In recognition of the organization's Quality Management System which complies with

ISO 9001:2015

The scope of activities covered by this certificate is defined below

Design, Manufacture and Marketing of Vibration, Shock and Seismic Control Systems

Certificate Number: 18762/A/0001/IN/In			
Date of Issue of Certification Cycle	Issue Number	Certificate Expiry Date	Certification Cycle
29 June 2022	5	24 June 2025	4
Revision Date	Revision Number	Original Certificate Issue Date	Scheme Number
01 May 2022	0	23 June 2021	n/a

For detailed explanation for the data fields above, refer to <http://www.urs-holdings.com/logos-and-regulations>

Issued by



On behalf of the Schemes Manager





CERTIFICATE OF APPRECIATION



Dear RESISTOFLEX PVT LTD,

Sub: Thank you for your support for our space launch

At the outset, we are happy to inform you of the huge success of our Vikram-S space launch project, Prarambh, which took place on 18 November 2022 at Sriharikota.

While we are proud of our landmark accomplishment and excited at the overwhelming response we are getting from far and near, we are cognizant of the strong support and contribution of vendors and partners like yourselves, without which the project wouldn't have been as successful.

At this moment of joy, we would like to greatly appreciate your unstinted support and sincere efforts towards the project, as a highly dependable supplier of quality products which helped us create a world-class launch vehicle like Vikram-S.

We look forward to your support for our forthcoming projects as well.

Thanking you,



Warm Regards,
Pawan Kumar Chandana
Co-Founder
Skyroot Aerospace

Skyroot Aerospace Private Limited, Hive Space, Divine Babylon Towers, Whitefields Road, Kondapur, Hyderabad-500084, Telangana, India
CIN: U74999TG2018PTC125073

EQUIPMENT SPECIALISATION CENTRE

It is hereby to state that M/s Resistoflex, NOIDA have been recognized as a center of excellence on shock mounts. The equipment specialization centers is created to interact directly with industries so as to acquire experience and knowledge on host of manufacturing etc., in order to make it meaningful, a document in brief and specific to serve the intended purpose be prepared under the following group heading w.r.t shock mounts and forward the same on priority to this office immediately:

- Intended purpose of Equipment
- Design principles
- Guidelines
-
-

Resistoflex, NOIDA
have been recognized as a
Center of Excellence on Shock Mounts.
Commander - QAO
Warship Equipments

(H.P. JOHN)
COMMANDER
QUALITY ASSURANCE OFFICER (WE)

AVS Chari, MS (Marine Engg) (UK)
former Associate Director, Scientist 'G',
MOD, DRDO, NSTL,
Member BOS, JNTU &
AUC, Andhra University

Phone : 9490149041
email : charinstl@gmail.com

TO WHOMSOIT MAY CONCERN

Sri S.N. Bagchi, Head-Technical Design, M/s. Resistoflex Private Limited, New Delhi has

made a commendable contribution in designing most efficient Shock & Vibration control for

first of its kind Nitrogen Plant, developed by M/s. Kirloskar Pneumatic Company Limited, Pune.

The plant is very complex with weight upto 23 tons. Sri S.N. Bagchi has come out with an innovative configuration, which is simple, rugged and efficient and economical.

Sri S.N. Bagchi, Head-Technical Design, M/s Resistoflex Private Limited, New Delhi-NCR has made a commendable contribution in designing most efficient Shock & Vibration Control for first of its kind Nitrogen Plant, developed by M/s Kirloskar Pneumatic Company Limited, Pune.

I wish him all the best in future.

Thanking you,

Yours faithfully,

(AVS CHARI)
Former Scientist 'G'
NSTL, DRDO



RESISTOFLEX GROUP

Corporate House

A-7, SECTOR-2, NOIDA - 201 301

Regd. Off & Plant. A-7, Sector 2, Noida, Uttar Pradesh CIN : U74899UP1992PTC183075



resistoflex

STOCKISTS & REPRESENTATIVES

AHMEDABAD: 9227419844, CHENNAI: 7200618555, 9841295276, KOLKATA: 9831032788,
MUMBAI: 9167245537, 9819841344, NEW DELHI: 9801075849, VISAKHAPATNAM: 9440277852

REGIONAL OFFICE PUNE : Mobile : 98900 35205

E-mail : sales@resistoflex.in

www.resistoflex.in

Mob.: 98182 00361 - 364

ISO 9001